

변경 사항			
기호	변경 내용	날짜	수정 승인
△			
△			

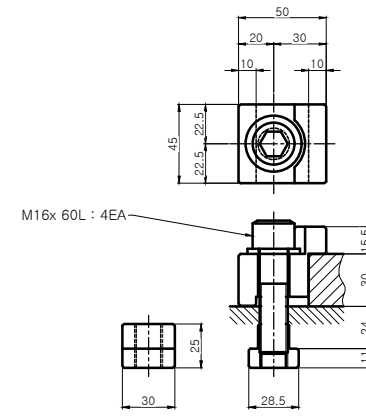

CLAMPING PARTS ACCESSORY 4 PAIR

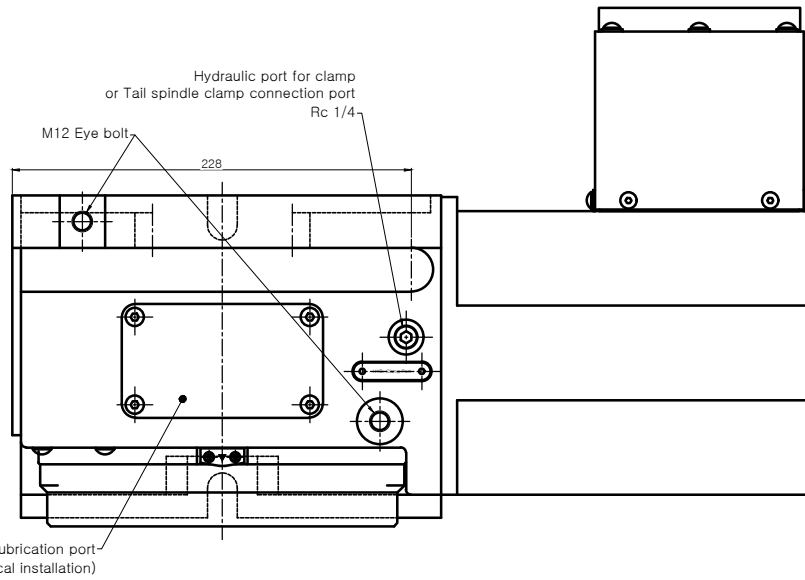
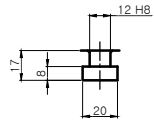
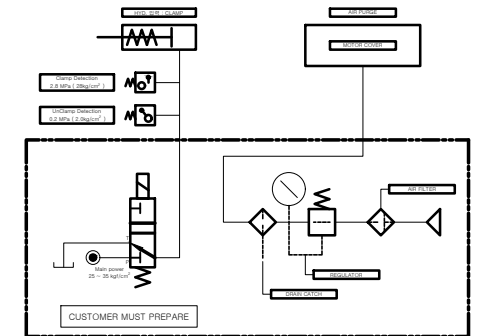
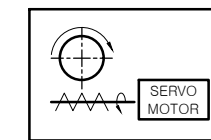
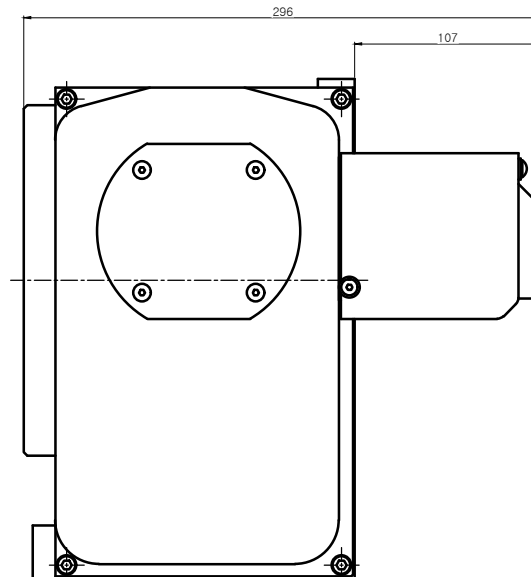
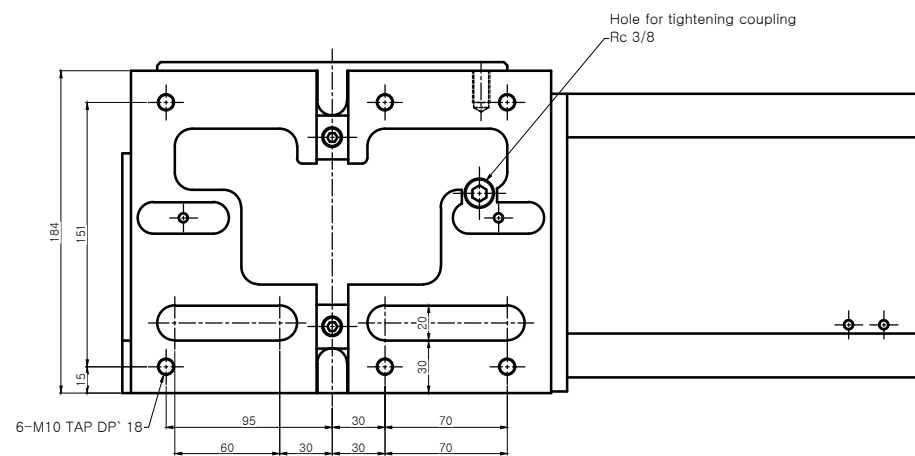
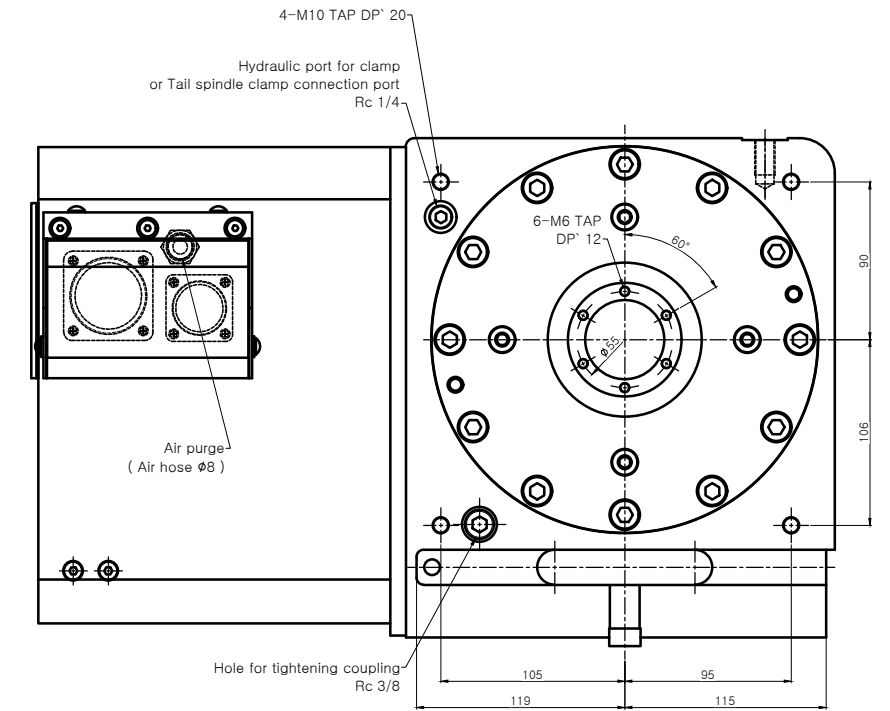
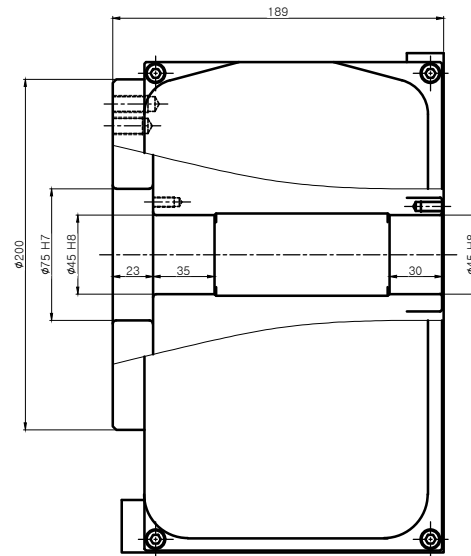
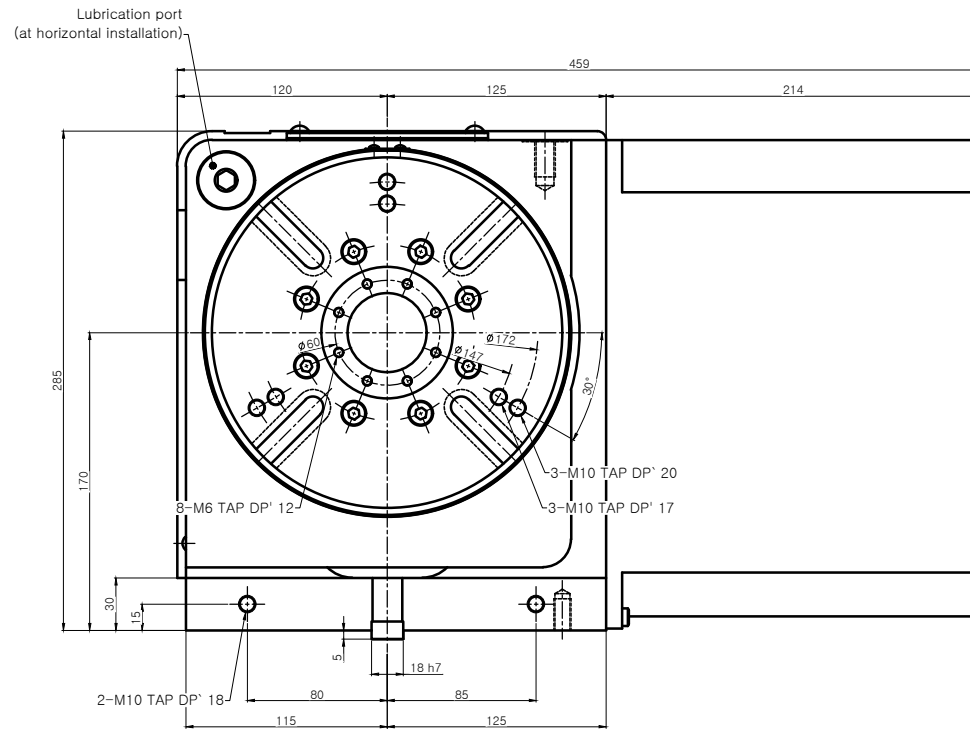
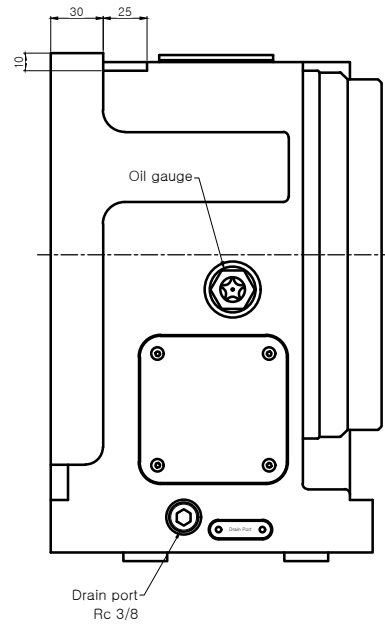

TABLE T-HOME



SPECIFICATION	
테이블 직경 Table Diameter	φ200 mm
센터 높이 Center Height	170 mm
테이블 내경 Table Inner Diameter	φ75H7
관통경 Spindle Through Hole Diameter	φ45H8
클램프 방식 Clamp Method	Hydraulic 25 ~ 35 kgf/cm <sup>2</sup>
관성 모멘트 Allowable Work Inertia	0.5 kg·m <sup>2</sup>
클램프 토크 Clamp Torque	720 N·m
회전 속도 Max. Spindle Speed	33.3 min <sup>-1</sup> (MOTOR MAX 3000 min <sup>-1</sup> )
기어비 Gear Ratio	1 / 90
무게 Weight	88 kg
기어 오일 Gear Lubrication	ISO VG #220
하중 한도 ALLOWABLE MASS OF WORK	200 kg [ HOR. ] 100 kg [ VER. ]

TITLE	Nc Rotary Table	PART NAME	외 형 도
DRG. NO.	HRS-204F4-00	USER	-
CODE NO.	-	DEPARTMENT	Research & Development
SCALE	1 : 1	DATE	2013. 08. 13
	Approved	Checked	Designed

